

Evaluation of Perceptual Countermeasure Treatments

*Jemima Macaulay, Michael Tziotis (ARRB TR)
Brian Fildes (MUARC)*

ABSTRACT

Perceptual countermeasures is a term given to a class of road treatments which are intended to induce drivers to reduce travel speeds by altering driver perception of speed, risk or comfort. They are generally low cost treatments which rely on painted markings or other forms of delineation.

ARRB Transport Research, in conjunction with the Monash University Accident Research Centre (MUARC), trialed two perceptual countermeasure treatments for the Australian Transport Safety Bureau (ATSB) in association with the Roads and Traffic Authority of NSW and VicRoads. The trials marked the final of a four phase project investigating perceptual countermeasure treatments and their applicability in Australia. Based on the findings of a comprehensive literature review and simulation studies, two perceptual countermeasure treatments were selected for trial. The first treatment consists of enhanced lateral guide post spacing with ascending heights around a curve. The second treatment is a peripheral transverse line (occurring on the edges but not in the centre of the travelling lane), placed at regular intervals over 400m on the approach to an intersection. Each treatment has been trialed in Victoria and New South Wales. In Victoria, the treatments were also investigated during night time driving conditions.

The present paper outlines the key findings of the first three stages of the study, and reports the results of the trials of the two perceptual countermeasure treatments.

Evaluation of Perceptual Countermeasure Treatments

Jemima Macaulay, Michael Tziotis (ARRB TR)
Brian Fildes (MUARC)

1 INTRODUCTION

Speeding has been long recognised as a major factor in the occurrence and severity of road crashes. Studies overseas and in Australia have identified speed as a factor in about 30% of fatal road crashes.

While enforcement, education/publicity and engineering programs have assisted in reducing speed related road trauma, supplementary measures to reduce the incidence of unsafe speed behaviours, particularly at hazardous locations, have been sought. A study was undertaken by Fildes and Lee in 1993 to assess needs for further research and action to reduce excessive speeding. A key outcome of the study, which involved leading experts across Australia, was the need to develop low cost perceptual countermeasures designed to reduce driver speed on roads.

2 DEFINITION

Perceptual countermeasures (PCMs) against excessive speeding refer to manipulations of the road scene presented to a driver that can influence his or her subsequent behaviour. For the most part, these treatments tend to be relatively low cost additions or modifications to the road or immediate roadside setting that can lead to change in the way the driving environment is perceived by drivers. A typical example would be a pattern painted on the road surface to induce the illusion that one is travelling much faster than without the treatment. (Godley et al 1999).

3 PROJECT BACKGROUND

The evaluation of perceptual countermeasures or Perceptual Safety Treatments (PST), conducted jointly by ARRB TR and MUARC, commenced in 1993 in the form of a four phase research program.

The first stage was a literature review of perceptual countermeasures by Fildes and Jarvis (1994). This revealed a range of road treatments likely to affect a driver's perception of speed on the road, some of which had been trialed overseas. These included transverse lines, herringbone and checked patterned edgeline treatments and/or medians, low contrast rumble centreline and edgelines, and raised pavement markers. While some of these treatments had been evaluated in terms of their crash reduction and/or behavioural change, the majority of them had not. Moreover, a systematic study of their relative effectiveness had not been carried out to date, including consideration of whether these treatments are necessarily optimal in reducing travel speed on the road.

The second stage of the project was a simulation validation study (Fildes, Godley, Triggs & Jarvis 1997). The driving simulator was formerly owned by the Transport Accident Commission of Victoria, but was donated to Monash University Accident Research Centre in July 1998. The validation study compared driving through perceptual treatments (transverse rumble strips) on roads in an instrumented vehicle with driving through the same treatments on the simulator. This test was done on the approach to two intersections and two curves. The investigation concluded that mean speed and lateral position were valid dependent measures to use on the simulator when evaluating PCMs.

The third stage of the project was evaluations of a range of PCMs using the driving simulator, which included:

- transverse road markings;
- lane edge and herringbone treatments;
- the Drenthe province treatment from the Netherlands;
- centreline and other edgeline treatments; and
- several enhanced curvature treatments.

Drivers drove a series of test tracks which had previously been programmed to include similar treated and untreated road locations. Speed and lateral position measures were compared at both the treated and untreated locations. A number of the PCMs appeared effective at reducing travel speed, including:

- full-width transverse lines;
- peripheral transverse lines and lane edge herringbone treatments;

- hatched median (especially with a lane width narrower than 3 metres), with or without intermittent gravel edgelines;
- enhanced post spacings (possible ascending heights) for road curves.

The third stage of the study recommended the effects of the promising treatments be further evaluated on the road to demonstrate the speed reduction benefits, both immediate and longer-term, as well as their safety benefit.

The fourth and final stage of the study involved applying two of the more promising PCM treatments on a sample of mid-block and intersection locations and evaluating their effectiveness and cost-benefits. This paper reports on the results of the on-road trials of two perceptual countermeasure treatments.

4 ON ROAD TRIALS OF PERCEPTUAL COUNTERMEASURES

4.1 Treatments selected for trial

Facilitated by two workshops, consultations were held between the research team and a number of relevant traffic engineers, service people and representatives of the funding agencies to overview the findings from the research conducted in stages 1 to 3 and to select appropriate treatments for the Stage 4 research program. Two treatments were selected, one midblock treatment and one intersection treatment.

4.1.1 Curve Treatment: Enhanced lateral guidepost spacings with ascending heights

The first treatment consists of enhanced lateral guide post spacing with ascending heights around a curve. To the approaching motorist, the configuration and ascending height of the guideposts makes the curve appear sharper than it is, inducing the driver to negotiate the curve at a lower speed. The technical specifications of the curve treatment are shown below.

Figure 1: Curve treatment

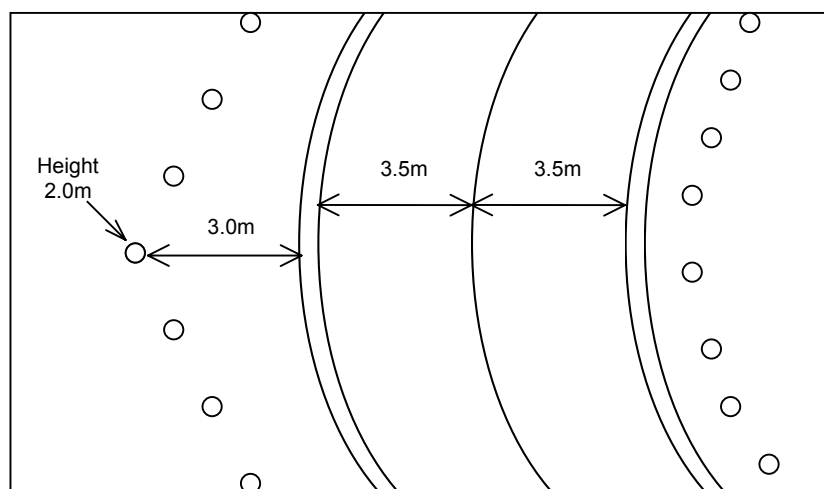

Treatment description:

- Treatment start/finish at the start/finish of curve.
- Guideposts around outside of curve spaced at half the normal spacing.
- Lateral placement of the guide posts increases evenly from the usual offset (typically 1.2 m) at the start of the curve, to 3m at the centre of the curve, then reduce back to the usual offset at the end of the curve.
- The height of the guide posts increases evenly from 1m (ie normal height) at the start of the curve, to 2m at the centre of the curve, then reduce back to 1m at the end of the curve.
- Guide posts are standard timber or flexible posts, painted white etc.
- Two reflectors provided on each guide post – one approximately 50 mm from the top of post and one at 1m height.
- No changes to the guide posts on the inside of the curve.

4.1.2 Intersection Treatment: Peripheral transverse line treatment

The second treatment is a peripheral transverse line (occurring on the edges but not in the centre of the travelling lane), placed at regular intervals over 400m on the approach to an intersection. Such treatments are designed to encourage drivers to decelerate more rapidly than usual by influencing their perception. They can also encourage drivers to maintain a central position within the traffic lane. The technical specifications of the intersection treatment are shown below.

Figure 2: Peripheral transverse line treatment on approach to intersection

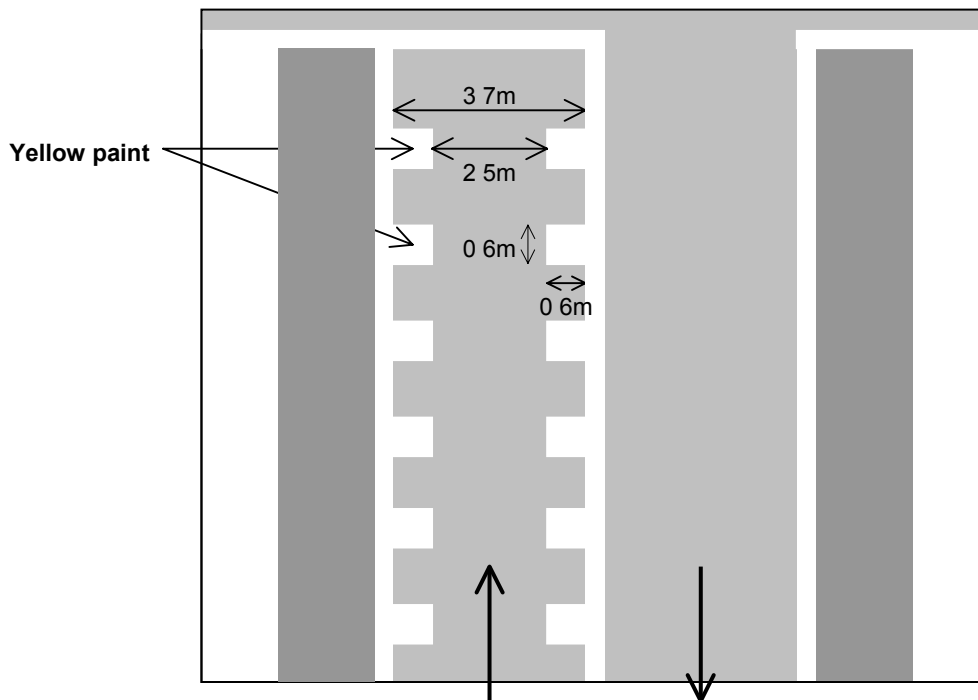

Treatment description:

- Treatment starts approximately 435m from intersection, and extends over 400m (ie. nothing over 35m immediately prior to intersection).
- Peripheral transverse lines are 600 mm wide, 600 mm long, with a 4.5m gap between parallel lines. Note that the distance between lines (across the lane) varies depending on the lane width.
- Lines to be yellow paint (not long life).
- Where there is no existing centre line, a centre line is installed with the treatment (standard 3m-9m dashed centre line) and continues to intersection (solid for last 30m or so).

4.2 Study design

The evaluation of the midblock and intersection treatments at each site comprised the following tasks:

- making a number of observations, namely, braking distance, lateral position in lane and speed (at varying points) at the treatment sites, and then comparing these observations and measurements to sites of similar geometric and geographic characteristics which were to remain untreated (ie control sites).
- collecting and analysing both pre and post-crash data at both treatment and control locations

Observations were made at both the treatment and control sites before installation of the treatments, 1-2 months after installation, and again 12 months after installation of the treatments. This enabled the effects of each treatment to be evaluated, both before and after installation, while controlling for traffic differences at the sites. The inclusion of two evaluation periods at 1-2 months and 12 months after installation enabled both short and long-term effects to be determined.

4.3 Site selection

Three trial treatment sites and three control sites in Victoria and in NSW were selected for each treatment, totalling twelve sites in each state. The sites were selected on the basis of the following considerations:

- For the intersection sites: a long, straight lead up to a cross or T-intersection where vehicle speeds would not be influenced by other factors and where the intersection may be somewhat unexpected.
- For the curve sites: a curve where vehicles may misjudge the speed required to negotiate it, based on its appearance or the preceding road geometry.
- For the control sites: features to match the treatment site, in terms of geometric, geographical and traffic characteristics, as closely as possible.

4.4 Performance Measurement

The site observations and measurements were made using CAMDAS (Video Vehicle Detection System owned by ARRB Transport Research), for braking behaviour and lateral positioning observations, and a speed laser gun for speed measurements. This unit is ideally suited for this work as it enables discrete observations of traffic behaviour to be made, without influencing driver behaviour.

Video recordings of all vehicles that transversed each treatment and control site over a duration of four hours was undertaken for each survey period, providing a permanent performance record for analysing at a later time. A series of trials was also conducted at night, to identify differences in the effectiveness of each treatment under different light conditions and also to assess the magnitude of these differences where they existed.

5 DATA ANALYSIS

5.1 Speed Data

Statistical analysis was undertaken for the speed data, using a factorial or three-way Analysis of Variance (ANOVA). This enabled the interactions between the three independent variables – site type (treatment or control), survey period (before, immediately after, or long term), and road segment (in 20m intervals) – to be studied.

5.2 Braking Data

In many cases, it was not clear from the video when, or if, a vehicle's brake lights came on. Therefore, it was not always possible to determine whether a vehicle did not brake, or whether a vehicle braked but at an unknown distance from the intersection or start of curve. This resulted in a small number of observations recorded at many sites.

Descriptive statistics were calculated for the car braking data, at each site across each survey period (ie. average braking distance, standard deviation, variance). In general, the braking data did not satisfy the assumptions required for parametrical significance testing.

5.3 Lateral Positioning

The lateral placement of vehicles was summarised into the following three categories:

- centre of lane
- left edge or combination of centre and left edge of lane
- right side or combination of centre and right side of lane.

The lateral positions of vehicles during the before, immediately after, and long term observation periods, at the treatment and control sites, was compared.

5.4 Crash Data

Before and after comparisons of crash data at each treatment and control site were undertaken. It would have been ambitious to expect significant crash reductions at only 6 treatment sites over a 12 month period, even if the treatments had large effects. However, the crash data was sought to show any apparent hints or trends of crash effectiveness. Obviously, more sites and longer observation periods would be preferable in terms of establishing significance of any crash trends.

6 RESULTS

6.1 Curve Sites

6.1.1 Average Vehicle Speeds

In terms of vehicle speeds averaged across the observed road sections, and in comparison to the before data, the results indicated the following:

Short term

- At four of the six treatment sites there was a significant increase in average vehicle speed immediately after installation of the treatment. Of the matched control sites, there was a significant increase in average vehicle speed at one site, no change at one site, and a significant decrease at two sites.
- At two treatment sites there was no significant change in average vehicle speeds immediately after installation of the treatments, and also no changes at the matched control sites.

Long term

- At five of the six treatment sites there was no long term change in average vehicle speed. Of the matched control sites, there was a significant increase in average vehicle speed at two sites, no change at two sites, and a significant decrease at one site.
- At one treatment site there was a significant increase in average vehicle speed in the long term, however there was a greater increase at the control site.

While the results do not indicate that the curve treatment has been effective in reducing average vehicle speeds in the short term, the long term results are more promising. It would appear that, in the long term, the treatment has had a positive effect on reducing vehicle speeds, relative to the control sites, at three of the six sites, and no effect at two sites. At the other treatment site, average vehicle speeds were no higher following the installation of the treatment.

Night observations

The night time observations, undertaken at two treatment and control sites, give contradictory results. At both control sites, there are no significant changes in average vehicle speeds for the before, immediately after or long term periods. At the Pakenham Road treatment site, there is a decrease in the average vehicle speed immediately after the installation of the treatment, but no long term change. At Gembrook Road there is a significant increase in average vehicle speed immediately after installation of the treatment and in the long term. This may suggest that drivers are more comfortable negotiating the bend, following installation of the treatment on Gembrook Road.

6.1.2 Braking Behaviour

The analysis of braking data did not give any indication of changes in braking behaviour by motorists approaching the curve sites. This is partly because the number of braking observations was small in many cases, and the standard deviation of braking distances was large.

6.1.3 Lateral Positioning

There is considerable variability in the lateral positions of vehicles approaching the curve sites during each observation period, at both the treatment and control sites. Therefore it is not possible to draw any conclusive trends in lateral vehicle positioning due to the curve treatment. However, it is noted that there was an increase in cars tracking towards the left side of the lane at both the left and right curve treatment sites following the installation of the treatments (immediately after and long term).

6.1.4 Crash Data

All treatment and control sites, except one, had no reported casualty crashes in the three year period before installation, and one year period after installation of the treatments. Therefore, the crash analysis does not give any indication as to the improvement in safety, or otherwise, resulting from the treatments.

6.2 Intersection Sites

6.2.1 Average Vehicle Speeds

In terms of vehicle speed averaged across the observed road section at the control and treatment sites, and in comparison to the before data, the results have shown the following:

Short Term

- The results of the short term effects of the intersection treatment on average vehicle speeds are inconsistent, with significant increases in vehicles speeds at two treatments site, no change at one site and a decrease at one site.

Long Term

- At four of the six treatment sites, there was no significant change in average vehicle speeds from the before period to the long term period. At the matched control sites, there were significant increases in average speed at two sites, no change at one site, and a decrease at one site.
- At one treatment site there was a significant increase in average vehicle speed in the long term, however there was a greater increase at the control site.
- At one of the treatment sites, there was a significant decrease in average vehicle speed, but no analysed speed data for the matched control site for comparison.

While the results do not indicate that the intersection treatment has been effective in reducing average vehicle speeds in the short term, the long term results are more promising. It would appear that, in the long term, the intersection treatment has had a positive effect on reducing vehicle speeds, relative to the control sites, at three of the six sites, and no effect at one site. At another site, the treatment also appeared to have been effective in reducing average speed in the long term, but there is no comparable control data. At the other treatment site, average speeds were no higher following the installation of the treatment.

Night observations

The night time observations, undertaken at one site, did not give any statistically significant results, possibly indicating that the treatment had no effect on vehicle speeds when it was dark. It is, however, unwise to draw any conclusions from the observations taken at just one site.

6.2.2 Braking Behaviour

The analysis of braking data did not give any indication of changes in braking behaviour by motorists approaching the intersection sites. This is partly because the number of braking observations was small in many cases, and the standard deviation of braking distances was large.

6.2.3 Lateral Positioning

Given that there was considerable variability in the lateral positions of vehicles approaching the intersection sites during each observation period, at both the treatment and control sites, it is not possible to draw any conclusive trends.

6.2.4 Crash Data

While casualty crashes were recorded at four treatment sites and three control sites during the four year period analysed (three years before and one year after installation of the treatments), the crash numbers are too small to give any indication of crash reduction trends.

7 CONCLUSIONS AND RECOMMENDATIONS

At both the curve and intersection treatment sites, the results indicate that the PCMs have not been effective in reducing average vehicle speeds in the short term, however the long term results are more promising.

At the curve sites, it would appear that, in the long term, the curve treatment has had a positive effect on reducing average vehicle speeds, relative to the control sites, at three of the six sites, and no effect at two sites. At the other treatment site, the average vehicle speed was no higher following the installation of the treatment than before.

At the intersection sites, it would appear that, in the long term, the intersection treatment has had a positive effect on reducing average vehicle speeds, relative to the control sites, at three of the six sites, and no effect at one site. At

another site, the treatment also appears to have been effective in reducing average speed in the long term, but there is no comparable control data. At the other treatment site, average speed was no higher following the installation of the treatment than before.

Given that the PCMs were not effective in the short term, but that there were positive long term effects on average vehicle speeds at three of the curve sites and four of the intersection, it is possible that drivers took some time (ie. more than 2 months) to change their driving behaviour. It is noted that, at all of the sites, the majority of traffic is local and most drivers would probably be very familiar with the road. It may be that perceptual treatments take longer to effect the driving behaviour of regular road users who are not actively looking for advanced cues of road geometry.

The analysis of braking behaviour and lateral vehicle positioning did not demonstrate any effect of the perceptual treatments.

8 REFERENCES

Fildes, B.N., Jarvis J.R. (1994) *Perceptual Countermeasures: Literature Review*. CR4/94 FORS and RTA NSW, November 1994

Fildes, B.N., Godley, S., Triggs, T. and Jarvis, J.R. (1997) *Perceptual Countermeasures: Simulator Validation Study* CR 169 (FORS) and RR 1/97 (RTA NSW), April 1997

Godley S., Fildes B., Triggs T. & Brown L. (1999). *Perceptual Countermeasures: Experimental Research*, Report CR182, Australian Transport Safety Bureau, Commonwealth Department of Transport and Regional Services, Canberra.

9 ACKNOWLEDGEMENTS

The authors wish to acknowledge the assistance of Bruce Corben of MUARC for his assistance in the selection of trial sites in Victoria and New South Wales.